

SmartFan® Cirrus-6

Speed Control and Alarm for 4-Wire Fans

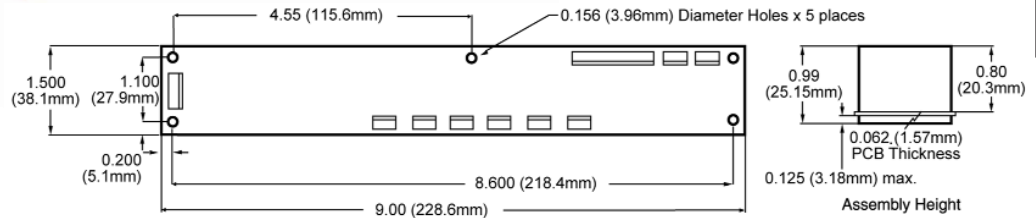
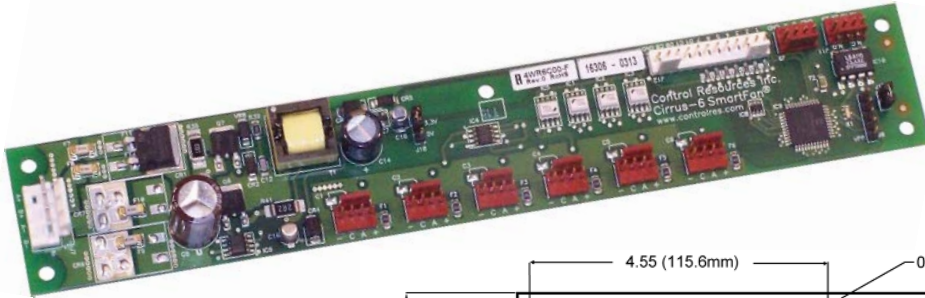

SmartFan Cirrus-6 is a digital fan speed control and alarm that offers an off-the-shelf cooling solution for 4-wire DC fans and blowers. Cirrus-6 can control and monitor tach pulses from up to six 12, 24 or 48 VDC fans. The controller accepts fan speed commands (including on/off) and provides individual pass/fail fan status via an I2C interface. The I2C interface also provides temperature readings from an on-board thermistor and EEPROM storage. The Cirrus-6 can be configured to control fan speed based on temperature or analog control signal (PWM, 5.0 VDC). Configuration of the Cirrus-6 is settable via I2C interface or options can be set at the factory to your specifications.

SPECIFICATIONS

- Power Source: 10 to 60 VDC, single or dual feed
- Current Rating: 6 Amps @ 60°C or less
- Power source is fused with reverse polarity protection
- Fans: Up to six 12, 24 or 48 VDC 4-wire fans
- On-board 3.3/5.0 VDC isolated power for I2C and control signal interfaces
- Storage temperature: -40°C to 125°C
- Operating temperature: -20°C to 60°C
- Temperature accuracy and hysteresis: 2°C
- Weight: 1.9 oz. (54 grams)
- RoHS (6/6) compliant

FEATURES/OPTIONS

- Power feed options:
 - Single
 - Dual diode OR'd (positive, negative, both)
- Control fans with open collector or 0-12 VDC control signal requirements
- Fan speed based on:
 - I2C interface (single or dual)
 - Temperature at an on-board or remote thermistor
 - Analog control signal (PWM, 5.0 VDC)
- Single or dual I2C interface capability:
 - Set fan speed control to be based on temperature or I2C commands
 - Write fan speed commands (including on/off)
 - Read pass/fail status for each fan
 - Read temperature readings from an on-board thermistor
 - Allow access to EEPROM storage
- Monitors open collector or voltage source tach pulses from the fans and provides pass/fail status for each fan through the I2C interface
- Compatible with SmartFan Multi SD for telecom 10 to 75 VDC dual feed buck regulator applications
- Optional individual fan fusing

PART NUMBERING

Part Number	Fan Control Signal
4WR6C00-F	Open collector PWM
4WR6V00-F	0-12 VDC PWM
H125-F	Hardware Pack

SmartFan Cirrus-6 Datasheet

FEATURES

Input Power: Cirrus-6 can accept a single or dual power source in the range of 10 to 60 VDC and supply up to 6 amps to the fan load at 60°C.

Input Power ORing: The dual power feed is diode OR'd on the positive feed.

Input Power Fuse: The input power line is fused at 10 Amps.

Fan Speed Control: Cirrus-6 is designed to control 4-wire fans. The supply voltage is fed directly to the fans and Cirrus-6 provides speed control signals (open collector or 0-12 VDC PWM) to the fans.

Number of Fans: Cirrus-6 can be configured to control and monitor 1 to 6 fans.

Fan Control Methods: Two methods of controlling fan speed are settable via the I2C Bus: temperature sensor (thermistor) input or I2C Bus input. Following is a description of each control method:

1) Temperature Based Fan Control: The speed of all fans is proportional to the temperature sensor connected to header J12, or the board mounted sensor. Figure 1.0 shows fan speed as a function of sensed temperature. I2C Bus register 0xF9 is used to set the control temperature, T_c (The control temperature is the temperature at which the full speed control signal is applied to the fans). Temperature sensor status and temperature readings are available on the I2C Bus.

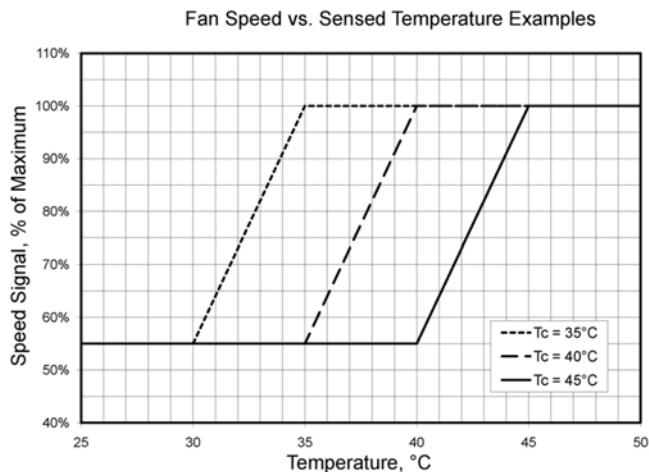

Figure 1.0: Fan speed signal vs. sensor temperature (5deg slope).

2) I2C Bus Based Fan Control: When an I2C speed command is given, the Cirrus-6 automatically switches to I2C control mode for fan control via the I2C Bus. The speed of all fans is mapped to the command sent through the I2C on header J12. See the Operation Section for a full definition of the I2C protocol.

Temperature Sensors: When temperature sensor based fan control is specified, the user can choose remote mounted sensor(s) or the board mounted sensor.

Selectable Control Temperature and Slope: When temperature sensor based fan control is specified, the user can set the control temperature and choose a 5°C or 10°C slope via the I2C Bus.

Selectable Off Temperature: The user can select an off temperature, which will set the control signal to 0% when the temperature drops below the set point.

Selectable Alarm Temperature: The user can set the alarm temperature. When the temperature exceeds the alarm temperature, an alarm is triggered and a full speed control signal is applied to the fans.

On Board Power Supply: An isolated 3.3/5.0 VDC is provided on board to power the I2C Bus and control signal interfaces.

Standard Configuration of the Cirrus-6

Cirrus-6 is intended to be configured via an I2C Bus. If no I2C Bus is connected, the Cirrus-6 will default to temperature based speed control as follows.

- Temperature is monitored by the remote sensor
- Control (full speed) temperature is 40°C
- Temperature slope is 5°C
- Idle speed (temperature below 35°C) is 55%
- Fan alarm is set at 2000 PPM with 6 fans
- LED and MOS alarms are active for fan alarms and external sensor failure (open)
- Fan control signal PWM frequency is 2.5kHz
- Fan control signal PWM output is 0-12 PWM for 4WR6V00-F and open collector output PWM for 4WR6C00-F

If your system does not utilize an I2C, the Cirrus-6 can be configured at the factory for special temperature control parameters. Contact Control Resources' application engineering for assistance.

Specialized Configurations of the Cirrus-6

- Can be readily modified to control most speed controllable (4-wire) fans with frequency and output drive
- Capability to provide different control parameters for two groups of fans (i.e. internal and external fans in a heat exchanger)
- Relationship between sensed temperature and fan speed control signal
- Additional temperature sensor inputs
- Analog control input (voltage/PWM control)
- Fan speed control based on differential temperature
- Fan speed alarm trigger point
- I2C bus status register
- Individual fan fusing
- Diode ORing (Negative feed, both feeds, none)

SmartFan Cirrus-6 Datasheet

Customized Configuration of the Cirrus-6

Contact Control Resources' application engineering with special or custom requirements.

INSTALLATION

Mounting

Using the PCB support hardware in hardware pack H125-F, or equivalent, mount the Cirrus-6 on a flat surface using all five mounting holes for maximum support.

Connector Pin Assignments:

A description of the function of each connector pin and location is listed in Table 1.0. Depending on the model number and configuration of the Cirrus-6, some headers may not need to be populated.

Header	Label	Description
J7	A+	A Power Supply Positive Terminal
	B+	B Power Supply Positive Terminal
	A-	A Power Supply Negative Terminal
	B-	B Power Supply Negative Terminal
J1- J6	-	Fan, Negative Terminal
	C	Fan, Speed Control Signal
	A	Fan, Tachometer Signal
	+	Fan, Positive Terminal
J12	1	I2C Address A0
	2	I2C Address A1
	3	I2C Address A2
	4	Speed Override Input
	5	Not Used
	6	Not Used
	7	External Thermistor Input
	D1	SDA for Secondary I2C Bus
	C1	SCL for Secondary I2C Bus
	D0	SDA for Primary I2C Bus
	C0	SCL for Primary I2C Bus
	GND	Isolated/Logic Ground
J11	1A	NC MOS Relay
	1B	NC MOS relay
	2A	NO MOS Relay
	2B	NO MOS Relay
J9	GND	Green LED Cathode
	G	Green LED Anode
	R	Red LED Anode
	GND	Red LED Cathode

Suggested Connecting Hardware

Use CRI Hardware Pack H125-F containing the following components shown in Table 2.0.

Header	Mfg. & P/N	H125-F Hardware Pack		
		Qty	Description	Mfg. & Part No. ¹
J7	Molex No. 26-60-4040	1	Housing	Molex No. 09-50-8041
		4	Terminal (tin)	Molex No. 08-50-0106
J1 - J6	Molex No. 22-29-2041	6	Housing	Molex No. 22-01-3047
		24	Terminal (gold)	Molex No. 08-55-0102
J12	Molex No. 22-29-2121	1	Housing	Molex No. 22-01-3127
		12	Terminal (gold)	Molex No. 08-55-0102
J9 & J11	Molex No. 22-29-2041	2	Housing	Molex No. 22-01-3047
		8	Terminal (gold)	Molex No. 08-55-0102
		5	PCB Support	Richco No. CBS-4-19

¹ Or equivalent

Input Power Connection to Header J1

Refer to Figure 2.0 for input power wiring. Input Power in the range of 10 – 60 VDC should be connected at header J7. Cirrus-6 can supply up to 6.0 Amps (still air) to the fan load at 60°C. Power to the fan load is derated linearly from 6.0 Amps to 4.0 Amps as temperature increases from 60°C to 75°C. Maximum operating temperature is 75°C.

Fan Connection to Headers J2-J7

Six Fans: Cirrus-6 distributes power to and monitors the tachometer signals from up to six four-wire fans. Referring to Figure 2.0, connect the fans to headers J1 through J6. Please check fan datasheet for color-coded wiring. Fan current at each fan header must not exceed 4.0 Amps. Total current required by the fans connected to the Cirrus-6 must not exceed 6.0 Amps.

Less than Six Fans: Through the I2C Bus, each fan header may be disabled. When disabled, the alarm outputs associated with that fan header will always show no alarm.

SmartFan Cirrus-6 Datasheet

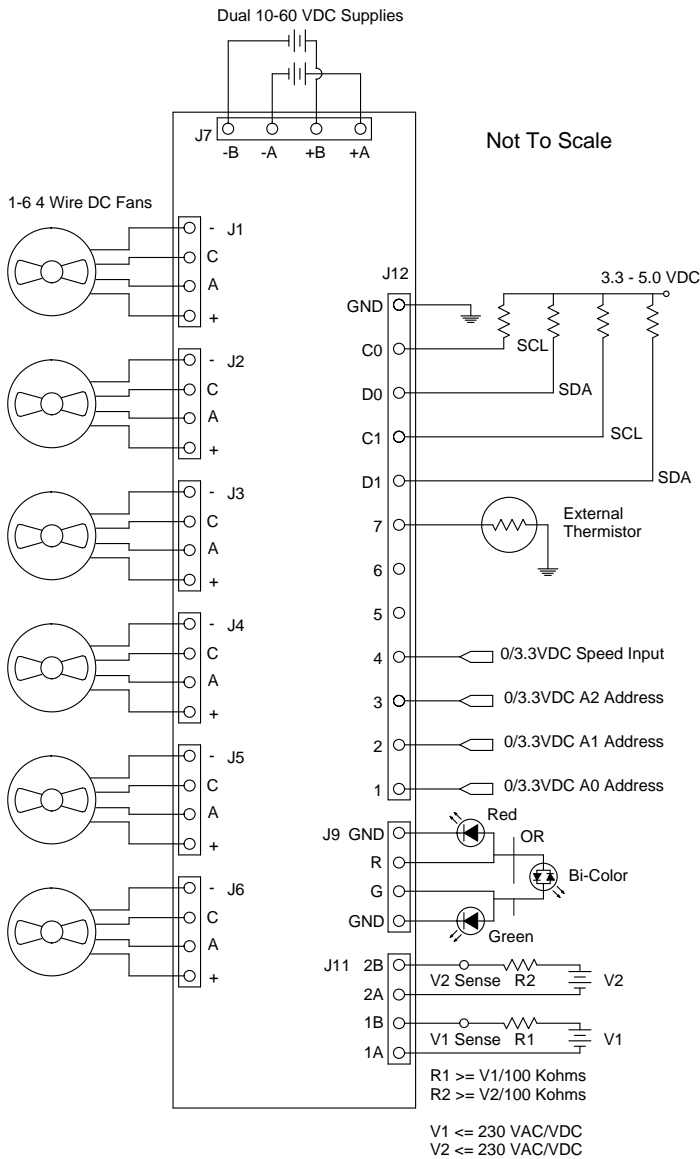

Figure 2.0: Connection diagram showing input power, fan, interface, temperature sensor, LEDs and alarm connections for a Cirrus-6 Fan Control.

Connection of Remote Temperature Sensor to header J12

Temperature Sensor Connection when I2C Control is used: When configured to operate with I2C based speed control, temperature readings from both sensors are available. These temperatures do not affect speed or alarms in this control mode.

Temperature Sensor Control: The Cirrus-6 can be configured to operate with either an external sensor or the on-board sensor, which is used to provide temperature based fan speed control and alarming. Referring to Figure 2.0, connect the external sensor if used to header J12. There is no polarity consideration when connecting the sensor. Temperature accuracy and hysteresis is 2°C.

Connection of Dual I2C Bus to Header J12

I2C Bus Speed Command Inputs when Temperature Sensor based Fan Control is used: When configured for temperature sensor based fan control, header J12 will accept I2C commands from either I2C Bus. If a speed control command is given the Cirrus-6 will automatically switch to I2C based speed control mode. Temperature sensor based fan control configurations support all I2C alarm status registers.

Dual I2C Bus: Cirrus-6 uses 3.3 or 5.0 VDC bus operation selected by the jumper on J10. The SCL (Pin Cx) and SDA (Pin Dx) total pull-up must be limited to 3 mA and Bus capacitance limited to 400 pf per the I2C specification. If only one I2C Bus is required either connection may be used. If two conflicting commands are given on each Bus at the same time the command from the Primary Bus will be used (S0 & D0).

Digital Inputs: The Speed input (Pin 4) and the ID inputs (Pins 1 - 3) are internally pulled to 3.3 VDC with 10.0KΩ resistors.

GND (Pin GND): Ground reference pin for the I2C Busses and digital inputs.

Connection of LEDs to Header J9

Header J9 provides local indication of Alarm (Pin R) and Normal (Pin G) status. Referring to Figure 2.0, connect alarm LEDs to header J9. Choose single color LEDs or two leaded, bi-color LEDs with a rated forward voltage (V_f) between 1.6 and 2.4 VDC at a forward current (I_f) of between 15 and 25 mA. Nominal current applied to the LEDs is 8 mA.

Connection of Remote Alarm Circuits to Header J11

A dual MOS relay is provided on header J11. Pins 1A and 1B output is closed on no alarm. Pins 2A and 2B output is open on no alarm. The alarm circuits on header J11 are isolated from all other pins and have no polarity. These outputs have a maximum on-state resistance of 50Ω. Maximum sinking current is 100mA. A maximum of 230 VAC/VDC can be applied to alarm terminals.

Current Derating:

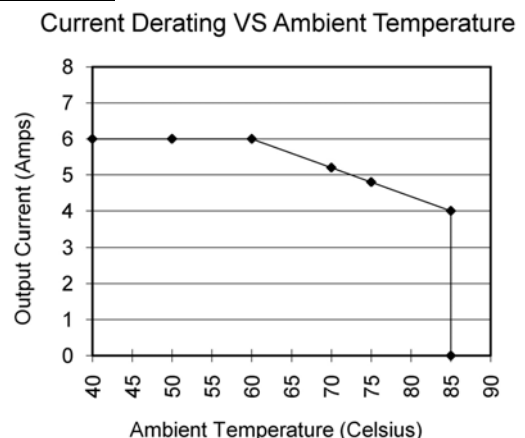

Figure 3.0: Current Derating

SmartFan Cirrus-6 Datasheet

OPERATION

Remote Sensor Selection (J12)

When configured to operate with a remote external temperature sensor, choose a compatible SmartFan Sensor shown in the SmartFan Catalog or at www.controlres.com/sensors.htm. Control temperature is set through the I2C Bus.

Board-Mounted Temperature Sensor

In this configuration, the fan control signal is proportional to the temperature at the sensor that is soldered to the Cirrus-6. Control temperature is set through the I2C Bus.

Fan Tachometer Setting

Since fan tachometer circuits are designed with one, two or even more pulse outputs per revolution, settings are listed in pulses per minute (PPM) rather than revolutions per minute (RPM). Given the fan's speed under load (W) and the number of pulses per revolution (N), use the following formula to select the trigger speed (W_A):

$$W_A = W \times N \times 0.3$$

For example, a 3300-RPM fan with two pulses per revolution would have a trigger speed of

$$W_A = 3300 \text{ RPM} \times 2 \text{ PPR} \times 0.3 = 1980 \text{ PPM.}$$

Since the 2000 PPM trigger is closest, set tachometer speed to 2000 PPM.

The alarm trigger accuracy is +/- 10%.

The Cirrus-6 default factory setting is 2000 PPM.

Led Output Status Operation (J9)

LED outputs at J9 pins labeled R, G and K for their respective cathode connections are provided as follows:

Red LED is energized for any fault condition.

Green LED is energized when no fault is present.

Two leaded and three leaded (common cathode) bi-colored LEDs can also be used.

Alarm Logic (J11)

A dual isolated Alarm output is provided on J11. Pins 1A and 1B output is closed on no alarm. Pins 2A and 2B output is open on no alarm. An alarm is also provided on power failure. These outputs have a maximum on-state resistance of 50Ω. Maximum sinking current is 100mA. A maximum of 230 VAC/VDC can be applied to alarm terminals.

Fan Control Signal in any Alarm Condition

During the presence of any alarm condition, except power failure, the full speed signal is applied to the fans.

Speed Override Input (J12 – Pin 4)

A logic level input is located on J12 that allows the user to command the fans to full speed when a ground level is applied. If this input is set to 3.3 VDC or open then the speed is set by its normal operating mode. Refer to Figure 2 for wiring details.

I2C Bus Protocol

The I2C Bus is configured as a slave device that can transmit and receive data. When the Cirrus-6 is configured for I2C based speed control, the user can write speed commands to the Cirrus-6 and read all alarm status bits. When configured for temperature based control the user can read all alarm status bits from the Cirrus-6. Writing an I2C speed command changes the control mode from temperature based to I2C based.

Specifications

- The Bus supports seven-bit addressing and only acts as a slave device.
- The address for the fan controller is 0001A2A1A0.
- General call support is not provided.
- The fan controller will stretch the clock further if needed. The I2C master must observe clock stretching.
- The hardware register will support Standard Mode I2C with speeds up to 100 KHz, however, lower clock speeds are recommended for increased noise immunity.
- If temperature control mode is disabled and I2C speed mode is used, then I2C communication must occur within ~2 minutes of the last communication, or there will be an I2C communication timeout error. When an I2C timeout occurs, full speed will be applied to the fans, and fan speed must be reset with a new speed command. Performing any valid I2C operation on either bus will clear the timeout condition and restart the watchdog timer.
- Fan failure based on 2000 minimum PPM of fan in slow (default) mode or 4000 minimum PPM in fast mode. Fan failure is not updated when the output is set to 0%.
- It is possible for noise to cause the I2C hardware to miss an address or data. In this case an Ack will not be generated. The production tester allows 3 errors to occur before marking the board as failing. Also during the EEPROM write cycle the I2C will not generate ACK signals as no more data can be accepted until the write cycle is complete. Typical write cycle is 8ms.

Table 3.0 defines the bits used in the serial bus protocol.

Table 3.0: I ² C Bus Definitions	
ACK	Acknowledge
ACK	Not Acknowledge (End of Transmission)
A6 – A0	Address for Fan Controller, bits 6 – 0
D7 – D0	Data TO/FROM Fan Controller, bits 7 – 0
L7 – L0	Data location being accessed, bits 7-0
P	Stop Bit
R	Read Bit (1)
S	Start Bit
W	Write Bit (0)

SmartFan Cirrus-6 Datasheet

Write sequence

S A6 A5 A4 A3 A2 A1 A0 W Ack L7 L6 L5 L4 L3 L2 L1 L0
Ack D7 D6 D5 D4 D3 D2 D1 D0 Ack P

Read sequence

S A6 A5 A4 A3 A2 A1 A0 W Ack L7 L6 L5 L4 L3 L2 L1 L0
Ack P S A6 A5 A4 A3 A2 A1 A0 R Ack D7 D6 D5 D4 D3 D2
D1 D0 Ack P

Register Locations: L7-L0 Label (R/W) [initial condition]

Register 0x00 – 0xEF: Generic EEPROM storage (Read/Write)
[undetermined]

Register 0xF0: Firmware Revision (Read only) [00:current rev]

Register 0xF1: Alarm0 Status (Read only) [0x00]

D0: Status of fan on J1 (0=no fault, 1= fault)
D1: Status of fan on J2 (0=no fault, 1= fault)
D2: Status of fan on J3 (0=no fault, 1= fault)
D3: Status of fan on J4 (0=no fault, 1= fault)
D4: Status of fan on J5 (0=no fault, 1= fault)
D5: Status of fan on J6 (0=no fault, 1= fault)
D6: Always 0
D7: Always 0

Register 0xF2: Alarm1 Status (Read only) [0x00]

D0: Always 0
D1-3: Always 0
D4: Status of speed override (0=normal, 1=100%)
D5: Status of on-board sensor (0=connected, 1= open)
D6: Status of external sensor (0=connected, 1=open)
D7: Status of controlling sensor (0=valid, 1=alarm)

Register 0xF3: Temperature (Read only) [1111 1111] on-board sensor

D0-7: Temperature from 0 - 70 in degrees C in 0.5 deg steps
0xFF = temperature not read yet or open
(Temperatures above 70 are reported as 254)

Register 0xF4: Temperature (Read only) [1111 1111] external sensor

D0-7: Temperature from 0 - 70 in degrees C in 0.5 deg steps
0xFF = temperature not read yet or open
(Temperatures above 70 are reported as 254)

Register 0xF5: Current Target Speed (Read only) [0001 0100]

D0-7: 0x14 = 100%, 0x00 = 0%
(Commanded speed with alarm status override included)
(In temperature mode this register will read 0x14)

Register 0xF6: Current Speed (Read only) [0001 0100]

D0-7: 0x14 = 100%, 0x00 = 0%
(What the actual current voltage is)
(In temperature mode this register will read 0x14)

Register 0xF7: Commanded Speed (Read/Write) [1111 1111]

D0-3: 0x14 = 100%, 0x00 = 0%

0x00 – 0x14 = 0 – 100 %, 5% per step

If set to 0xFF then temperature mode is enabled and I2C speed control disabled

Register 0xF8: Off Temperature (Read/Write) [1111 1111]

D0-7: Temperature from 0 - 70 in degrees C in 0.5 deg steps
Temperature below which the controller turns off the fan output
(0 VDC)

If set to 0xFF then function disabled

Register 0xF9: Control Temperature (Read/Write) [0101 0000]

D0-7: Temperature from 0 - 70 in degrees C in 0.5 deg steps
Full speed temperature, only used if Commanded Speed set to 0xFF.

Register 0xFA: Alarm Temperature (Read/Write) [1111 1111]

D0-7: Temperature from 0 - 70 in degrees C in 0.5 deg steps
Temperature above which the controller alarms
If set to 0xFF then function disabled

Register 0xFB: Config0 Register (Read/Write) [0011 1111]

D0-D5: 0=Mask, 1=Active for an Fan (J1-J6)
D6-D7: Not Used

Register 0xFC: Config1 Register (Read/Write) [0000 0000]

D0: Not Used

D1-D4: Set to 0, may be set to 1 to allow system to indicate a fan controller reset.

D5: 0=5deg slope, 1=10 deg slope for temperature mode only

D6: 0=2000PPM tach, 1=4000PPM tach fan alarm speed

D7: 0=External, 1=On-board sensor selection for temperature mode only

Register 0xFD-0xFF: CRI Test Register (Reserved) [xxxx xxxx]

D0-7: Do not use

Note: If a fan failure occurs the Current Speed will be updated to full but the Commanded Speed will remain at its previous value. Once the failure clears the Current Speed will return to the Commanded Speed value. An I2C timeout changes BOTH the Current Speed and Commanded Speed to full. The Commanded Speed must be reset after a timeout. During the speed ramp the Current Speed will not match the Commanded Speed until the ramp completes.