

SmartFan® TachScan-3

Fan Speed Alarm

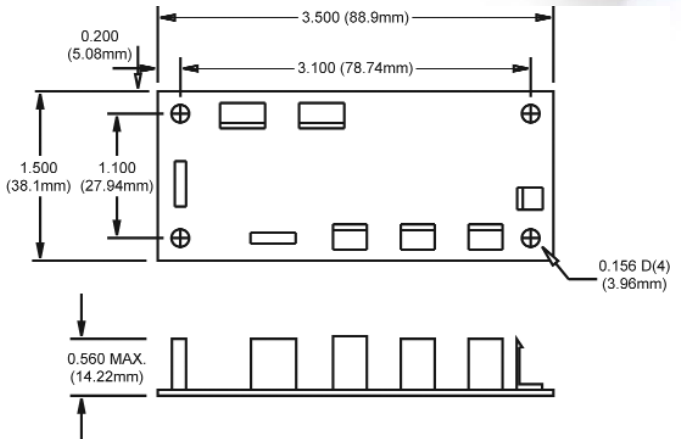
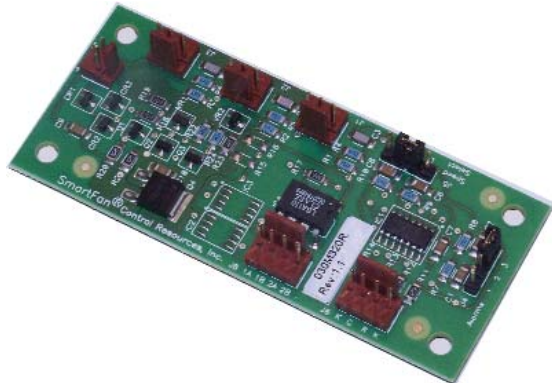

Alarms

SmartFan TachScan-3 is a digital fan speed alarm that monitors the tach pulses from up to three DC or AC fans or blowers and provides OR'd pass/fail signals. TachScan-3 is compatible with any fan that provides open collector or voltage source tach pulses. Three trigger speeds are selectable by jumper. If the speed of any air mover falls below the trigger speed, alarm signals are generated. Alarm signals can drive LEDs, logic, optical isolators or MOS Relays.

FEATURES

- P/Ns 030M320-F and 030M320R-F accept any supply voltage from 6 to 60 VDC and distribute power to DC fans through the same header used to sense tach pulses.
- P/Ns 030M3205-F and 030M320R4-F accept any supply voltage from 6 to 60 VDC and power the DC tach circuits built into AC fans
- Three inputs monitor fans with any open collector or voltage source tach pulses
- P/Ns 030M320-F and 030M3205-F provide simultaneous NO and NC open collector outputs from optical isolators which can sink up to 1.0 mA to drive logic circuits
- P/Ns 030M320R-F and 030M320R4-F provide simultaneous NO and NC isolated outputs from a Dual-Pole MOS Relay which can sink up to 100 mA to drive heavy loads
- Jumper sets trigger speed to 1,000, 2,000 or 4,000 PPM
- Can drive two single LEDs or one bi-colored LED
- Compatible with any SmartFan speed controller
- RoHS (6/6) compliant
- Small size of 3.5" X 1.5" permits mounting in small spaces within fan trays, etc.

SPECIFICATIONS

| Part Number | Fan Type | Isolated Alarm Sinking Current | Supply Voltage Range | Maximum Input Current | Maximum Output Current to Any Fan |
|-------------|---------------|--------------------------------|----------------------|-----------------------|-----------------------------------|
| 030M320-F | DC | 1 mA | 6 to 60 VDC | 4.0 Amps | 4.0 Amps |
| 030M320R-F | DC | 100 mA | | | 4.0 Amps |
| 030M3205-F | AC | 1 mA | | | N/A |
| 030M320R4-F | AC | 100 mA | | | N/A |
| H115-F | Hardware Pack | | | | |

Note: Maximum operating temperature is 65°C

For complete product details visit: www.controlres.com

TachScan-3 - Installation & Operation

INSTALLATION

Fan Connections

For three wire DC fans operating at supply voltages between 6.0 and 60.0 VDC, TachScan-3 distributes power to the fans in addition to accepting tachometer pulses from the fans. Connect the fan wires to J1, J2 and J3 using the suggested hardware, or equivalent. For applications using less than three fans, any of the three connectors (J1, J2, J3) can be used to monitor tachometer signals. The fan wires are usually color coded with red for +, black for - and white or yellow for A (alarm). Input current must not exceed 4.0 Amps. When TachScan-3 is used with a SmartFan speed controller, the power output of the speed controller is connected to J7.

AC Fan Alarm Monitoring

Order these part numbers when using TachScan-3 with AC fans.

P/N 030M3205-F for 1 mA Alarm Sinking Current
 P/N 030M320R4-F for 100 mA Alarm Sinking Current

TachScan-3 cannot distribute AC power to AC fans. AC fans usually have 5 wires, 2 for power and 3 for the tachometer pulse circuit. Connect the AC fan power leads to the rated source of power. Connect the tachometer pulse leads (+, -, tach pulse) to J1, J2, and J3. TachScan-3 distributes power to run the tachometer pulse circuits within the fans. Apply a DC voltage as specified by the fan manufacturer for the tachometer pulse circuits at J7.

Use with a SmartFan Speed Controller

Because of the wide range of power supply voltages that may be connected to J7, TachScan-3 may be used with any DC SmartFan speed controller. The power output of the speed controller that would otherwise be connected directly to the fan load is instead connected to J7. TachScan-3 in turn distributes this power to the fans.

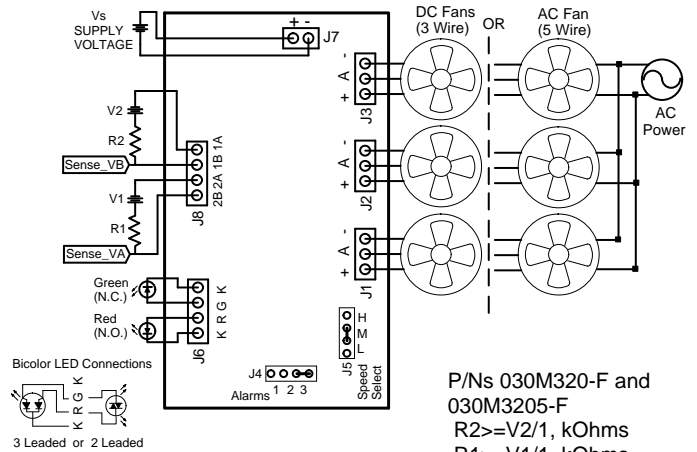

- J1 – Fan Power and Tach Input
- J2 – Fan Power and Tach Input
- J3 – Fan Power and Tach Input
- J4 – Alarm Channels Setting
- J5 – Trigger Speed Setting
- J6 – Alarm Outputs
- J7 – Supply Power

P/Ns 030M320-F and 030M3205-F
 $R2 \geq V2/1$, kOhms
 $R1 \geq V1/1$, kOhms
 P/Ns 030M320R-F and 030M320R4-F
 $R2 \geq V2/100$, kOhms
 $R1 \geq V1/100$, kOhms
 Above Trigger Speed
 Sense_VA = V1 VDC
 Below Trigger Speed
 Sense_VA = <0.4 VDC
 Sense_VB = V2 VDC

Figure 1.0 Typical wiring diagram.

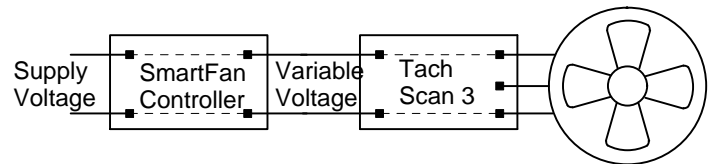

Figure 2.0 Multi-board configuration for variable fan speed control and tachometer alarm monitoring.

Suggested Connecting Hardware

| Ref. Desc. | Header on Board ¹ | H115-F Hardware Pack | | | |
|------------|------------------------------|----------------------|-----------------|---------------------------|--------------------------|
| | | Quantity | Description | Manufacturer ¹ | Part Number ¹ |
| J1, J2, J3 | 22-29-2031 | 3 | Housing | Molex | 22-01-3037 |
| | | 9 | Terminal (Gold) | | 08-65-0816 |
| J6, J8 | 22-29-2041 | 2 | Housing | Molex | 22-01-3047 |
| | | 8 | Terminal (Gold) | | 08-65-0816 |
| J7 | 22-29-2021 | 1 | Housing | Molex | 22-01-2027 |
| | | 2 | Terminal (Gold) | | 08-65-0816 |
| | | 4 | PCB Support | Richco | CBS-4-19 |

¹or equivalent

TachScan-3 - Installation & Operation

Hi-Pot Testing

When installed using ¼" spacers, all versions of the Tachscan-3 are designed to withstand a maximum voltage of 3000VDC or 3000RMS during Hi-Pot testing.

OPERATION

Settings Alarm Channel (J4)

Use this jumper to specify the number of fan tachometer signals that will be monitored, from 1 to 3. Each jumper setting label corresponds to the number of fans to be monitored. For example, if only two fan tachometer signals are going to be monitored set the jumper to the "2" position. The factory setting is "3."

Settings Trigger Speed (J5)

Use this jumper to set the trigger speed.

Position L = 1000 PPM
Position M = 2000 PPM (Factory Setting)
Position H = 4000 PPM

Since fan tachometer circuits are designed with one, two, or even more pulse outputs per revolution, settings are listed in pulses per minute (PPM) rather than revolutions per minute (RPM). Given the fan's rated speed (W) and number of pulses per revolution (N), use the following formula to select the trigger speed (W_A):

$$W_A = W \times N \times 0.4$$

(Note: When used with a SmartFan speed controller the factor in the above equation should be changed from 0.4 to 0.3.)

For example, a 3300 RPM fan with two pulses per revolution would have an trigger speed (W_A) of

$$W_A = 3300 \text{ RPM} \times 2 \text{ PPR} \times 0.4 = 2640 \text{ PPM}$$

Since the 2000 PPM trigger is closest, set jumper J5 to the "M" position.

The alarm trigger accuracy is +/- 20%.

LED Outputs (J6)

Both normally on (green) and normally off (red) LED outputs are provided. Two leaded and three leaded (common Cathode) Bi-colored LEDs can also be used. Choose LEDs with rated forward voltage (V_f) between 1.6 and 2.4 VDC at forward current (I_f) of between 15 and 25mA. Nominal current applied to the LEDs is 8mA.

Led Connections

| Pin | Function |
|-----|----------------------------------|
| K | Cathode |
| R | Active HI for red LED connection |
| G | Active LOW for green LED |
| K | Cathode |

Isolated Alarm Outputs (J8)

These outputs provide both normally open and normally closed isolated outputs permitting connection to logic circuits or other loads with no electrical connection to the TachScan-3 circuit.

Part Numbers 030M320-F and 030M3205-F provide simultaneous open collector outputs from optical isolators, which are intended to drive logic circuits. These outputs can sink up to 1.0 mA at 0.4 VDC. A maximum of 30 VDC can be applied to alarm terminals. The normally closed output also triggers in the event of cooling system power failure.

Part Numbers 030M320R-F and 030M320R4-F provide simultaneous outputs from a Dual-Pole MOS Relay, which are intended to drive heavy loads. These outputs have a maximum on-state resistance of 50 Ω. Maximum sinking current is 100 mA. A maximum of 230 VAC can be applied to alarm terminals. The normally open output also triggers in the event of cooling system power failure.

Isolated Output Connections

| Part No. | Pin 1A | Pin 1B | Pin 2A | Pin 2B |
|--------------------------------|---------------|-----------------|---------------|-----------------|
| 030M320-F & 030M3205-F | NC Emitter | NC Collector | NO Emitter | NO Collector |
| 030M320R-F & 030M320R4-F | NC | NC | NO | NO |

Note: At power-up, all outputs are held in the normal state for 10 seconds permitting the fans to come up to speed.