

SmartFan® Cirrus

Programmable Interface for Speed Controllable Fans



CRI #036BCT00-F
with DIN350-F DIN rail kit (sold separately).



CRI #036BCT00-F



CRI #036BJT00-F
with 4x4 Job Box (not supplied).

SmartFan Cirrus is a compact, microprocessor based PWM fan interface designed for the electronics, industrial and HVAC control markets. The Cirrus can automatically control most speed controllable (4 wire) 24 and 48 VDC fans used in applications such as: equipment cooling, humidity control, clean room pressurization, exhaust ventilators, duct fans & blowers. The Cirrus regulates fan speed from a 0-20mA-control signal, 0-10VDC-control signal, remote transducer or thermistor. On board programming, three mounting and connection configurations, including DIN rail mount and "4x4 job box" mount, make this design extremely flexible and economical.

FEATURES (off the shelf)

- Controls one or two 24 or 48 VDC open collector PWM controllable fans
- Power source: 20 – 60VDC (passed through to fan)
- Settable PWM frequencies between 1000Hz and 10,000Hz.
- Controls fans from a:
 - 0-20mA control signal
 - 0-10VDC control signal
 - Remote transducer (temperature, humidity, pressure, flow)
 - Remote thermistor (sold separately)
- Isolated control inputs
- Temperature & loss of signal alarm
- Tach alarm with 3 selectable speed settings
- Remaining fan switches to full speed upon fan failure
- Settable Max and Min fan speeds
- Settable Max and Min control signal
- Settable 0-18VDC supply voltage to drive external transducer or alarm
- Mounting Options: PCB mount, DIN Rail mount, 4x4 electrical job box mount
- Maximum operating temperature: 70°C
- RoHS (6/6) compliant

CUSTOMIZING OPTIONS

- Can be readily modified to control most any speed controllable 4-wire fan
- PWM frequencies below 1000Hz and above 10,000Hz
- Fused fan inputs
- Hard coded control curve
- Hard coded alarm trigger points
- Hard coded transducer supply voltage
- Dual thermistor and transducer inputs
- On board thermistor
- On board pressure transducer (1"H2O, 5"H2O)
- NEMA 4X case
- Connections: Terminal Block, 18 AWG wires.

For complete product details visit: www.controlres.com

SmartFan[®] Cirrus

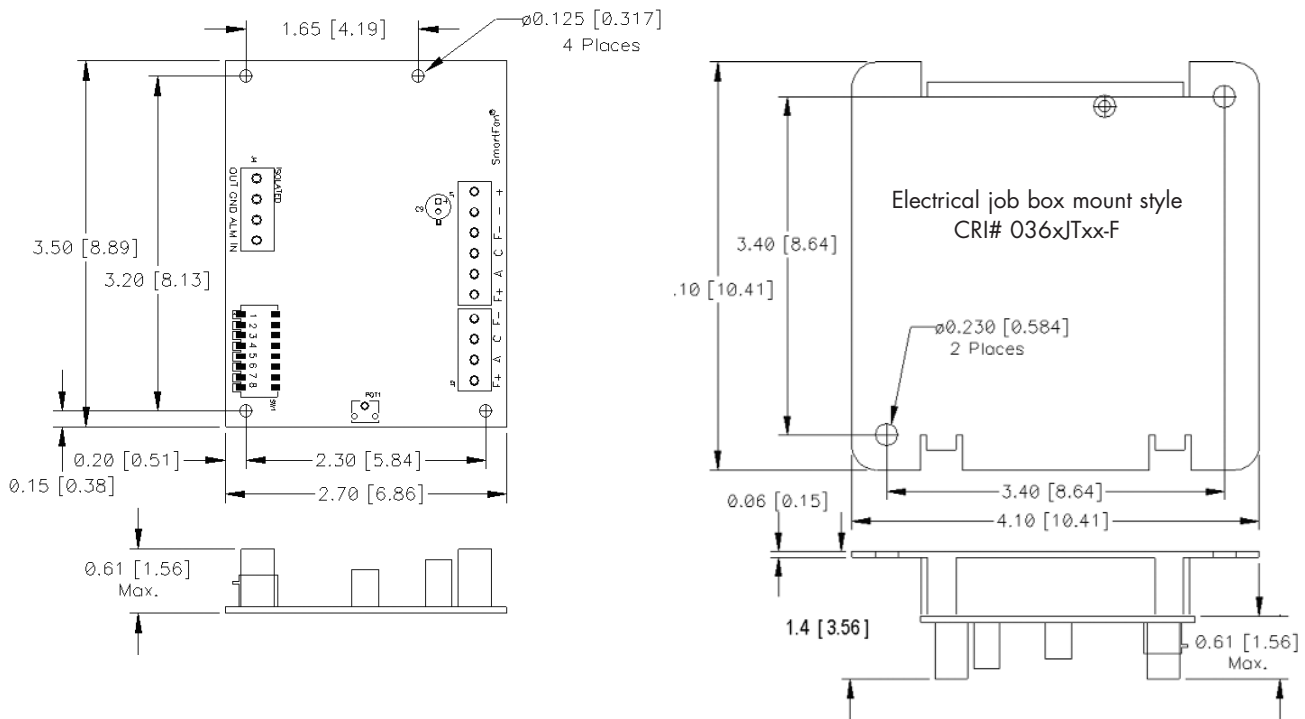

PART NUMBERING SYSTEM

Nominal Voltage	Control Mode	Configuration	Connector	Customized Options	RoHS Compliant
036	B = Current, Voltage, Thermistor ¹ or remote Transducer	C = Circuit Board Only J = Job Box Mount	T = Terminal Block ²	00 = standard	-F
DIN350-F	Din Rail Kit				

¹When used in the thermistor control mode, a sensor (sold separately) is required. Choose an air, surface or liquid temperature sensor from the CRI catalog or website at www.controlres.com.

²Maximum current rating is 10 Amps

Stock Product: 036BCT00-F

For complete product details visit: www.controlres.com



SmartFan Cirrus Datasheet

FAN COMPATABILITY

The off-the-shelf Cirrus is compatible with the common open collector PWM controllable fan. Most other control schemes can be accommodated with minor hardware modifications. To confirm fan compatibility, send CRI your speed controllable fan for analysis.

SETTING CONTROL MODES (switches #1,2)

Unless otherwise specified, the Cirrus is factory set to control fans in the voltage control mode. To control via a current or thermistor source, set switches 1 and 2 as shown below. If an on board pressure transducer or on board thermistor is required, contact customer service.

Control Via	DIP switch	
	1	2
Voltage Source	OFF	OFF
Current Source	ON	OFF
Thermistor Source	OFF	ON

SETTING NUMBER OF FANS (switch #3)

The Cirrus can control one or two fans. When controlling 2 fans, set switch 3 to the OFF position. For one fan, set switch 3 to the ON position.

SIGNAL LOSS OVERRIDE FEATURE (Switch #4)

If the control signal drops below 2% of the maximum control signal (for voltage or current control) or is lost due to a severed cable or loose wire (current or temp. control only), fans can automatically switch to full speed and an alarm will be triggered by placing switch 4 in the ON position. To keep fans from switching to full speed (Y2) in this event, place switch 4 in the OFF position. (see figure 6)

CUSTOMIZING YOUR CONTROL CURVE (figure 7)

The off-the-shelf Cirrus is designed to give the user optimum flexibility in experimenting with control parameters. Once the desired control parameters are chosen, the user may order their own customized version of the Cirrus preprogrammed with the desired control curve and other custom features avoiding switch and potentiometer settings. Refer to figure 7 when setting switches 5,6 and 7.

Until this point, all settings can be made without power, control signal or fans connected. From here on, the Cirrus must be powered, fans connected and an adjustable control signal (decade box or other resistance substitute to simulate a thermistor, an adjustable voltage source for voltage control or adjustable current source for current control or to simulate a transducer) must be connected to the board. (see **CONNECTIONS** section for details).

For steps A – H, switch 8 will activate and deactivate POT1 for programming, to avoid accidental programming errors be sure to deactivate POT1 by turning switch 8 OFF before changing switches 5,6 or 7.

A) Transducer or Alarm Power

When controlling from a remote transducer or powering an alarm, the Cirrus can be used as a power source up to 18VDC (see figure 9). If not powering a transducer or alarm, skip this step. To set the supply voltage, set switches 5-OFF, 6-OFF, 7-OFF (see table 3), then set switch 8 to the ON position. Place a multimeter across OUT and GND and adjust POT1 until the desired voltage is set. When finished, set switch 8 to the OFF position.

Settable Parameter	DIP switch		
	5	6	7
A) Trans. or Alarm Power (0-18VDC)	OFF	OFF	OFF
B) PWM Frequency	ON	OFF	OFF
C) Full Speed Duty Cycle (Y2)	ON	ON	OFF
D) Idle Speed (Y1)	OFF	OFF	ON
E) Minimum Control Point (X1)	ON	OFF	ON
F) Maximum Control Point (X2)	OFF	ON	ON
G) Fan ON/Fan OFF setting (X3)	ON	ON	ON
H) Tach alarm threshold	OFF	ON	OFF

B) Setting PWM Frequency

The standard Cirrus can control PWM controllable fans between 1000Hz and 10,000Hz. Check your fan for the specified PWM signal. To program for this signal, set switches 5-ON, 6-OFF, 7-OFF (see table 3), then set switch 8 to the ON position. Adjust POT1 for the closest setting to the PWM signal specified for your fan (see figure 6). When finished, set switch 8 to the OFF position. **Note:** POT1 settings are not graduated, knob alignment need not be exact.

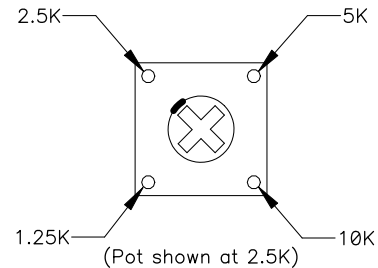

Figure 6

C) Setting Full Speed Duty Cycle (Y2)

With the fan or fans powered, adjust POT1 to the full speed required for your application (see figure 7). The appropriate speed can be determine using a strobe light, flow meter, sound level meter or measuring temperature rise, this is purely application specific. Set switches 5-ON, 6-ON, 7-OFF, then set switch 8 to the ON position. When finished, set switch 8 to the OFF position. **Note:** When determining Y2, make sure the air mover is loaded to simulate actual operation conditions. An air mover that is not loaded will provide inaccurate results.

D) Setting Idle Speed (Y1)

With the fan or fans powered, adjust POT1 to the idle speed required for your application (see figure 7). The appropriate speed can be determine using a strobe light, flow meter, sound level meter or measuring temperature rise, this is purely application specific. Set switches 5-OFF, 6-OFF, 7-ON, then set switch 8 to the ON position. When finished, set switch 8 to the OFF position. **Note:** When determining Y1, make sure the air mover is loaded to simulate actual operating conditions. An air mover that is not loaded will provide inaccurate results.

E) Setting Minimum Control Input (X1)

With the fan or fans powered, simulate the minimum control input (see figure 7) across J4, GND - IN using a resistance to simulate a thermistor (refer to table 4), voltage or current to simulate a transducer. Set switches 5-ON, 6-OFF, 7-ON, then set switch 8 to the ON position. Set switch 8 back to the OFF position.

F) Setting Maximum Control Input (X2)

With the fan or fans powered, simulate the maximum control input (see figure 7) across J4, GND - IN using a resistance to simulate a thermistor (refer to table 4), voltage or current to simulate a transducer. Set switches 5-OFF, 6-ON, 7-ON, then set switch 8 to the ON position. Set switch 8 back to the OFF position. **Note:** If X2 is set less than X1, it will default to the X1 setting.

G) Fan On / Fan Off Setting (X3)

With the fan or fans powered, simulate the control input required to turn fans on and off (see figure 7) across J4, GND - IN using a resistance to simulate a thermistor, voltage or current to simulate a transducer. Set switches 5-ON, 6-ON, 7-ON, make sure POT1 is not fully counter clock wise (CCW), then set switch 8 to the ON position. Set switch 8 back to the OFF position. **Note:** If X3 is set greater than X1 it will default to the X1 setting.

To override the fan on / fan off feature and have fans always at idle speed outside of the control region, set switches 5-ON, 6-ON, 7-ON, then set switch 8 to the ON position. Turn POT1 fully CCW then set switch 8 back to the OFF position.

H) Setting Tach Alarm Threshold

Most PWM controllable fans will indicate fan speed from a tachometer circuit that senses Pulses Per Revolution (PPM). The Cirrus can sense these pulses and send an alarm signal through J4 when a minimum threshold is reached. If no alarm is to be connected, skip this step.

To set the alarm threshold, set switches 5-OFF, 6-ON, 7-OFF, then set switch 8 to the ON position. Adjust POT1 to the desired PPM alarm threshold (see figure 8). When finished, set switch 8 to the OFF position. **Note:** POT1 settings are not graduated, knob alignment need not be exact.

Temperature		KΩ	Temperature		KΩ
°C	°F		°C	°F	
-15	5	173	30	86	15.8
-10	14	128	32	90	14.4
-5	23	96.2	34	93	13.1
0	32	72.6	36	97	12.0
5	41	55.3	38	100	10.9
10	50	42.4	40	104	10.0
12	54	38.2	42	108	9.16
14	57	34.5	44	111	8.40
16	61	31.2	46	115	7.70
18	64	28.2	48	118	7.07
20	68	25.5	50	122	6.50
22	72	23.1	55	131	5.27
24	75	21.0	60	140	4.29
26	79	19.1	65	149	3.52
28	82	17.3	70	158	2.89

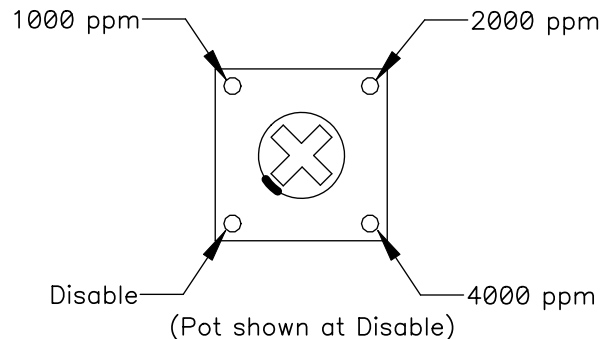

Figure 8 (POT1 PPM)

SmartFan Cirrus Datasheet

MOUNTING

Electrical “job box” mount (Fig 3)

The Cirrus can be supplied in circuit board form or with a cover, ready to mount in a standard 4x4x1.5 electrical job box. When supplied in the job box form, part number 036xJWxx , connections are made through 4.0” (10cm), 18AWG wires. Wires should be terminated using wire nuts (not included). Wires that are not used should be cut at the circuit board or individually terminated with wire nuts. See Figure 3 and Figure 5.

Circuit Board form (Fig 2)

When supplied in the circuit board form; 036xCxxx a spacing of ¼” (6.3mm) should be maintained between the circuit board and chassis ground and 5/16” (8mm) to any uninsulated secondary circuits to satisfy safety agency requirements. See Figure 4.

DIN Rail Option (Fig 1)

Units supplied in circuit board form; 036xCxxx may be mounted on a DIN rail using **DIN rail kit CRI #DIN350**.

CONNECTIONS (figure 9)

Power Connections

Connect power + to location J1, +. Connect - power to location J1, -. **CAUTION:** Reversing + and - may damage the control.

Fan Connections

The Cirrus is designed to control and provide tach alarm signals from one or two speed controllable fans. To connect one fan, J1 or J2 may be used. For two fans, connect one to J1 and one to J2. Connect the + lead to F+, connect – lead to F-, connect PWM signal lead to C, connect the tach signal lead to A. **Note:** the tach lead need not be connected if the fan speed alarm feature is not to be used.

For more than two fans use our SmartFan Cirrus-6 that can control up to six 4-wire fans.

Control Input Connections

Thermistor

Choose an air, surface or liquid temperature sensor from the CRI catalog or website at www.controlres.com. Connect to J4, IN and GND (polarity neutral).

Voltage or Current signal control

Connect 0 -10VDC or 0 -20mA control signal + to J4, IN and – to J4, GND. **CAUTION:** Reversing + and - may damage the control.

Remote Transducer

The Cirrus can control fan speed based on a remote transducer. For transducers that require 18VDC or less to power, the Cirrus can power the transducer as well. To connect and power a transducer, attach the supply voltage lead to J4,OUT attach the output voltage lead to J4, IN, attach ground lead to GND. To adjust a supply voltage for the transducer, see step A) Transducer or Alarm Power.

Alarm Conditions and Connections

For the off-the-shelf Cirrus, an alarm signal will be triggered if any of the conditions in table 5 are met. The Cirrus can also be preprogrammed at the factory to provide any number of custom alarm conditions and configurations.

Alarm Condition	Control Mode			
	Switch 4	Voltage	Current	Thermistor
Fan speed < tach alarm threshold	N/A	X	X	X
X2+10°C (18°F)	N/A			X
-20°C (-4°F)	ON			X
Control Signal < 2% of max.	ON	X	X	N/A
Severed Control signal	ON		X	X

The alarm output is a normally open (NO), open collector referenced to isolated ground. When no alarm condition is present, the relay is closed and can conduct up to 100 ma DC, of load current. When the alarm is triggered, the transistor opens, and can support up to 100 VDC across its terminals. See figures 9a, 9b, 9c or 9d for possible alarm configurations.

SmartFan Cirrus Datasheet

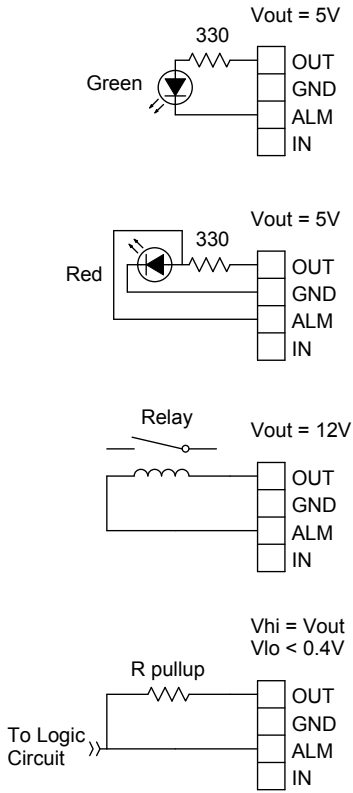

Figure 9a.-d.: Alarm Configurations

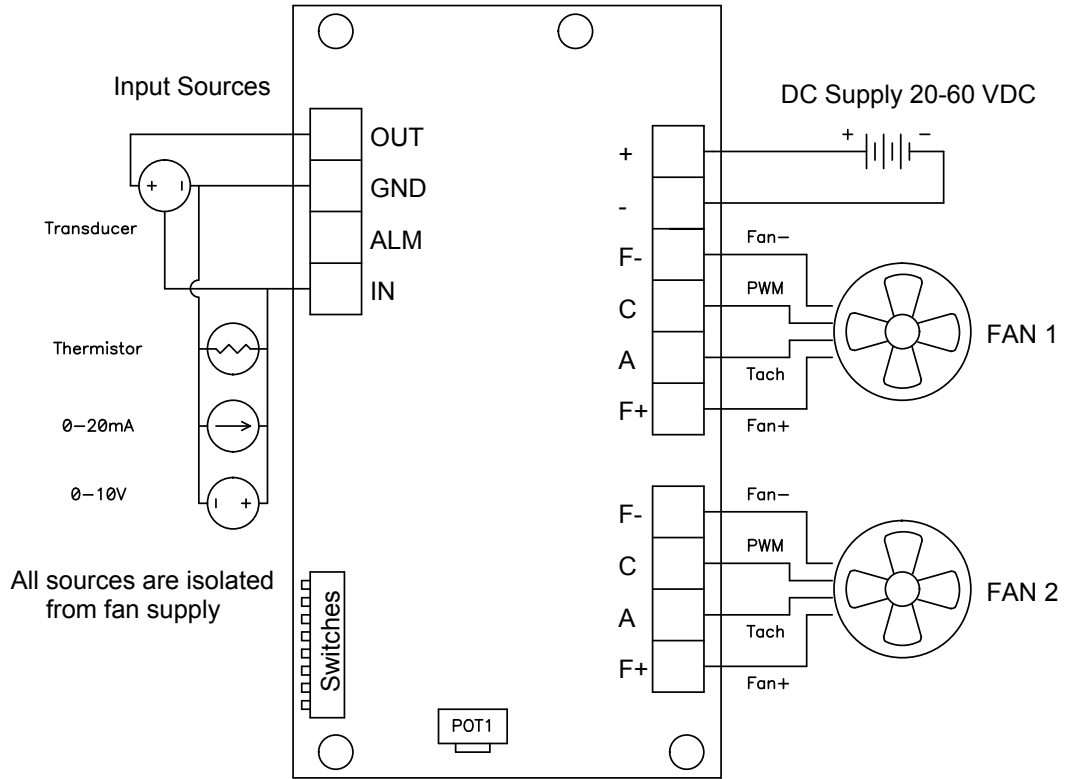

Figure 9: Wiring Diagram

Table 6: Pin-out and Connection Options			
Pin-outs		Connection Options	
Board Reference	Description	Terminal Block (T)	4"(100mm) Wire (W)
+: J1 (pin 1)	Power In +	16 – 26 AWG Screw Clamp	18 AWG Red
-: J1	Power In -		18 AWG Black
F-: J1	Fan -		18 AWG Blue
C: J1	Fan PWM		18 AWG Violet
A: J1	Fan Tach		18 AWG White
F+: J1	Fan +		18 AWG Orange
F-: J2 (pin 1)	Fan -		18 AWG Blue
C: J2	Fan PWM		18 AWG Violet
A: J2	Fan Tach		18 AWG White
F+: J2	Fan +		18 AWG Orange

IN: J4 (pin 1)	Control voltage / Thermistor	18 AWG Yellow
ALM: J4	Alarm Output	18 AWG Brown
GND: J4	Ground / Thermistor	18 AWG Green
OUT: J4	Transducer Supply Voltage	18 AWG Gray

SmartFan Cirrus Datasheet

TECHNICAL DATA

Control Accuracy and Hysteresis:

Temperature Mode:

High Temperature Alarm = $X2 + 10^{\circ}\text{C}$
Low Temperature Alarm = -20°C
Temperature Alarm Hysteresis = $\pm 1^{\circ}\text{C}$
Temperature Accuracy = $\pm 1^{\circ}\text{C}$ 0-50 $^{\circ}\text{C}$
= $\pm 2.5^{\circ}\text{C}$ -20-80 $^{\circ}\text{C}$

Voltage/Current/Transducer Mode:

Signal Loss Alarm Hysteresis = $\pm 1\%$
Idle Off Hysteresis = $\pm 2\%$
Input Accuracy = $\pm 5\%$

Tachometer:

Hysteresis = $\pm 3\%$
Accuracy = $\pm 1\%$

Specifications:

Power Source: 20-60VDC

Current Rating:

036xxTxx-F (terminal block) – 10A
036xxWxx-F (wires) – 7A

Storage Temperature: -40°C to 125°C

Operating Temperature: -25°C to 70°C

RoHS (6/6) Compliant

Control Resources has been a leading provider of off-the-shelf and custom fan controls and alarms since 1984. Control Resources can offer Thermal DC Speed Controls, AC Speed Controls, Tach Alarms and Fan Trays, Lab Test Equipment and complete custom design and manufacturing services. With in house ISO 9001 design and manufacturing capabilities, CRI is the One-Stop-Shop for all your thermal design needs. For information on other CRI products, see our website at www.controlres.com or contact Control Resources, Inc.