

SmartFan® Vortex

I2C Controller for 12VDC Fans

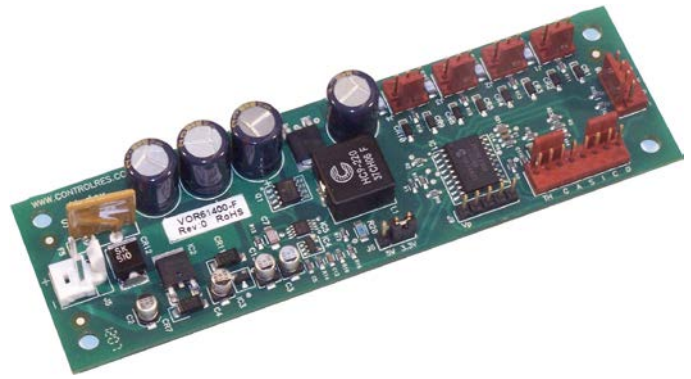

SmartFan® Vortex is an I2C controllable fan control designed for up to four 12VDC fans with a total current rating of 5 Amps. Fan control using 2 or 3 wire fans is achieved by varying the supply voltage using a current mode buck control circuit. The controller accepts fan speed commands (including on/off) and provides individual pass/fail fan and temperature status via an I2C interface. The Vortex can also be programmed via an I2C bus to control fan speed based on temperature. Additional features include: fan on/off temperature set point, temperature alarm and fan failure (low speed) alarm.

Part Number	Description
VOR5I400-F	Vortex Fan Controller (Rev:1.3+ saves control parameters automatically)
H122-F	Vortex Hardware Pack (optional)

Specifications

- Power Source: 9.6-14.4VDC
- Fans: Up to four 2-3 wire 12VDC fans, total current rating 5Amps @ 75°C
- Fan speed controlled by:
 - I2C interface or
 - Board Mounted Thermistor or
 - Remote thermistor (sold separately)
- Selectable 3.3 or 5.0VDC I2C power provided
- Operating Environment: -20°C to 75°C, 0-95% RH, non-condensing
- Storage Temperature: -40°C to 125°C
- Temp. accuracy & hysteresis: 2°C
- Weight: 37 grams (1.3 oz.)

Options

- Factory preprogramming
- Individual fan fusing
- Custom control slope
- Custom alarm trigger speeds

Features

- Power efficiency typically >90%
- I2C interface control Inputs:
 - Temperature or I2C control
 - Fan speed control curve
 - Fan on/off set points
 - Fan alarm trigger speed
 - Temp alarm trigger
 - 2 addresses
- I2C outputs
 - Temperature status
 - Fan alarm status
- Remote LED fan status output
- Remote fan status logic output
- External speed override input
- RoHS compliant
- 2 year warranty
- Made in the USA
- **CE** Certified. Ref. Installation section for conditions of acceptably

SmartFan Vortex Datasheet

DIMENSIONS (fig. 1)

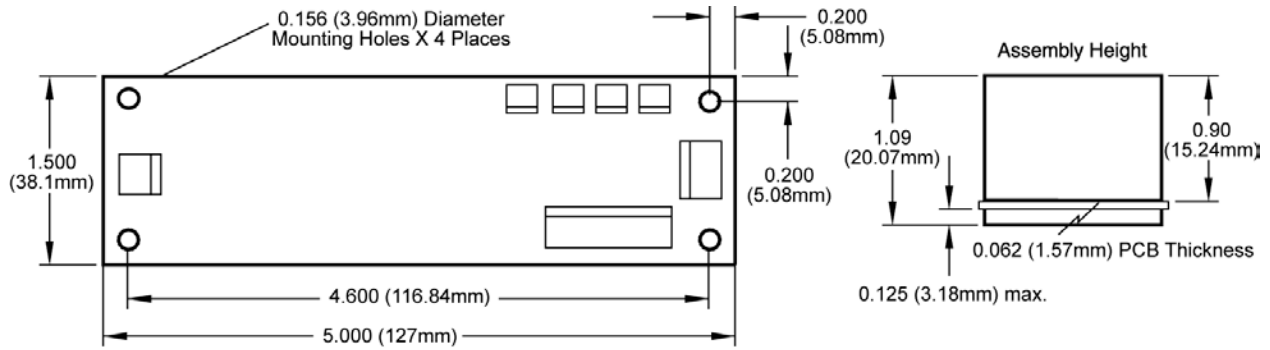

INSTALLATION

Mounting & Connecting Hardware:

For your convenience in lower volume applications, CRI sells an optional hardware pack, H122-F that includes typical connectors and mounting hardware (see below).

Table 1: Recommended Hardware				
Header	Mfg. & P/N	H122-F Hardware Pack		
		Qty	Description	Mfg. & P/N ¹
J5	Molex No. 26-60-4020	1	Housing	Molex No. 09-50-8021
		2	Terminal (Tin)	Molex No. 08-50-0106
J1 - J4	Molex No. 22-29-2031	4	Housing	Molex No. 22-01-3037
		12	Terminal (gold)	Molex No. 08-55-0102
J7	Molex No. 22-29-2081	1	Housing	Molex No. 22-01-3087
		8	Terminal (gold)	Molex No. 08-55-0102
J8	Molex No. 22-29-2041	1	Housing	Molex No. 22-01-3047
		4	Terminal (gold)	Molex No. 08-55-0102
		4	PCB Support	Essentra No. CBS-4-19

¹ Or equivalent

Mounting:

When mounting over a conductive surface, use a minimum spacer height of 5mm (.197") for proper electrical clearance. The Vortex meets EU directives

CE EN 60950-1 for safety and EN61000 class A for Emissions and Immunity when mounted in a conductive enclosure with at least 5 sides. The enclosure must also contain adequate venting for heat dissipation and limit finger access to the board.

CONNECTIONS

Connector Pin Assignments:

A description of the function of each connector pin and location is listed in Table 2. Note: some connection may not be required for your application.

Table 2: Connector Pin Assignments		
Header	Label	Description
J1- J4	+	Fan, Positive Terminal
	A	Fan, Tachometer Signal
	-	Fan, Negative Terminal
J5	+	Power Supply, Positive Terminal
	-	Power Supply, Negative Terminal
J7	D	I2C SDA
	C	I2C SCL
	I	I2C Address Id
	S	Cmos Speed Override Input
	A	Cmos Alarm Output
	G	Signal Ground
	TH	Temperature Sensor
	TH	Temperature Sensor
J8	-	Green LED Cathode
	G	Green LED Anode
	R	Red LED Anode
	-	Red LED Cathode

SmartFan Vortex Datasheet

Fan Connection to Headers J1-J4

The Vortex distributes power to and monitors the tachometer signals from four three-wire fans. Referring to Figure 2, connect the fans to headers J1 through J4. Common wire color codes are red for +, black or blue for - and white or yellow for tachometer signal (A). Fan current at each fan header must not exceed 4.0 Amps. Total current required by the fans connected to the Vortex must not exceed 5.0 Amps (still air) at 12 VDC. When connecting fewer than 4 fans it will be necessary to disable empty fan headers through the I2C for proper alarm function.

Input Power Connection to Header J5

Refer to Figure 2 for input power wiring. Connect 9.6 – 14.4VDC power to header J5. **Soft Start:** The voltage applied to the fans at start-up ramps to the nominal supply voltage then shifts to the commanded voltage. This “soft start” feature limits the current spike common to DC fans at start-up. Note: A 7.5 Amp re-settable input power fuse is provided to protect the Vortex from over-current conditions.

Selecting I2C Power Supply J6

3.3 or 5.0 VDC power to run the I2C Bus can be selected by the jumper setting on J6. The Vortex uses a common negative ground for all power and signal connections.

Remote Temperature Sensor J7-TH

One can use I2C to program a desired temperature curve and control fan speed from the on-board thermistor (T1) or remote thermistor sensor (sold separately) installed at location TH on header J7. When controlling fan speed via I2C one can still monitor temperatures from the on-board thermistor and in a remote location by adding a thermistor sensor at location TH/J7.

Connection of Remote Alarm Circuits to Header J7-A

The Alarm output (Pin A) is a push-pull CMOS output based on the VCC setting with a 562 Ohm limiting resistor. The output is set to VCC when there is no alarm and Ground during any alarm condition. The output is current limited by a 600Ω drive impedance. Referring to Figure 2, connect logic circuits to header J7. **All alarm circuits on header J7 are non-isolated from input power (J5).**

Connection of I2C Bus to Header J7-C,D,I

Internal VCC: The SCL (Pin C) and SDA (Pin D) are internally pulled to VCC with 10.0KΩ resistors. The total pull-up must be limited to 3mA and bus capacitance limited to 400 pf per the I2C specification. The Speed input (Pin S) and the ID input (Pin I) are internally pulled

to VCC with 10.0KΩ resistors. **GND (Pin G):** Ground reference pin for the I2C Bus. When configured for temperature sensor based fan control, header J7 will accept I2C commands. If a speed control command is given the Vortex will automatically switch to I2C based speed control mode. Temperature Sensor based fan control configurations support all I2C alarm status registers.

Speed Override Input (J7 – Pin S)

A non-isolated input is located at J7 that allows the user to command the fans to full speed when a ground level is applied. If this input is set to VCC or open then the speed is set by its normal operating mode. Refer to Figure 2 for wiring details.

Connecting Alarm status LEDs J8

Header J8 provides local indication of Alarm, normally off (R/red) and Normal, normally on (G/green) status. Referring to Figure 1.0, connect alarm LEDs to header J8. **All alarm circuits on header J8 are non-isolated from input power (J5).** Choose single color LEDs or two leaded, bi-color LEDs with a rated forward voltage (V_f) between 1.6 and 2.4 VDC at a forward current (I_f) of between 15 and 25 mA. Nominal current applied to the LEDs is 8 mA.

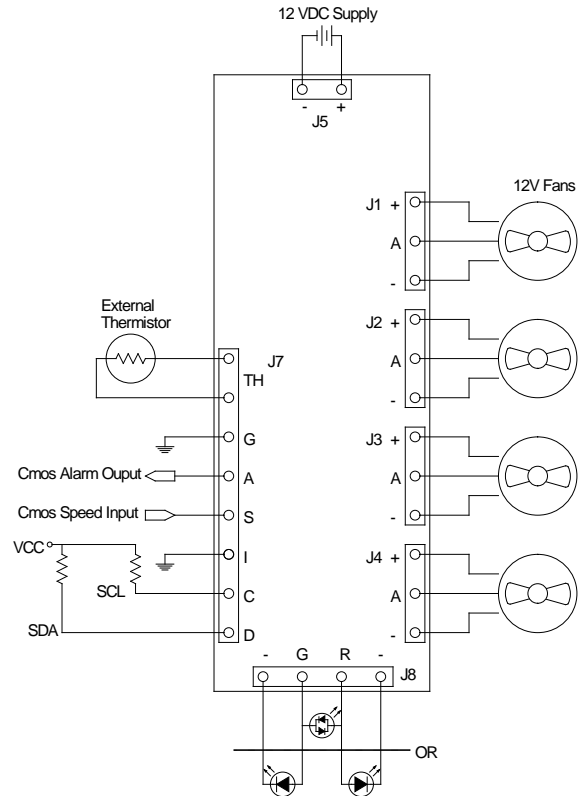

FIGURE 2: Vortex Connection diagram

SmartFan Vortex Datasheet

OPERATION

Temperature Based Fan Control: If no I2C Bus is connected, the Vortex will default to temperature based fan control. In temperature control mode the voltage powering the 4 fans will vary between 55% of the supply voltage and the supply voltage in an effort to maintain temperature at the temperature sensor connected to J7 between 35°C and 40°C (T_c), (ref. fig. 3). If fewer than 4 fans are connected or no temperature sensor is connected an alarm signal will be triggered and fans will switch to full speed. To reduce the number of fans controlled, change temperature control variables and program alarm settings, (ref. table 3) connect the I2C Bus.

- The number of fans connected is less than the number of fans programmed (4 fans is the default).

When an alarm is triggered, fans will switch to full speed, LEDs connected to J8 and a logic signal connected to J7 will change state (refer to CONNECTIONS section for details). An alarm state will also be signaled on the I2C Bus.

I2C Bus Fan Control: When an I2C speed command is given, the Vortex automatically switches to I2C control mode for fan control via the I2C Bus. The speed of all fans is mapped to the command sent through the I2C on header J7. See the Operation Section for a full definition of the I2C protocol.

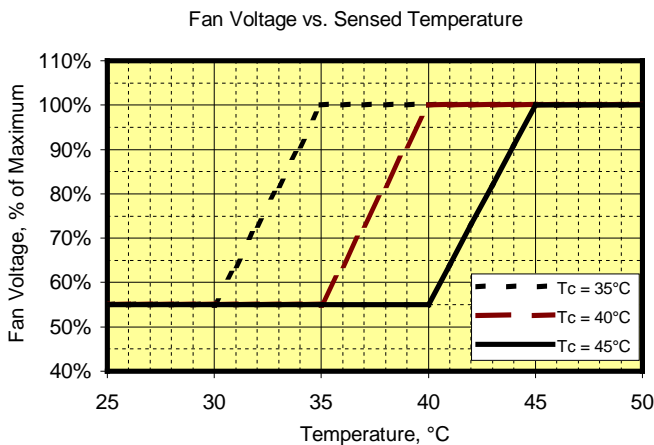

Fig.3: Fan voltage vs. temperature examples (5deg slope).

Table 3: Programmable Temperature Control Variables		
Variable	Range	Default
Number of fans	1-4	4
Alarm trigger speed	2,000 / 4,000ppm	2,000ppm
Temp. Slope	5°C / 10°C	5°C
Control Sensor	On-board/Remote	Remote
Control Temp. (T_c)	0°C - 70°C	40°C
Fan off temp.	0°C - 70°C	Disabled
Alarm Temp.	0°C - 70°C	Disabled

Alarm Conditions: An alarm signal can be triggered in the following conditions:

- Fan speed falls below the set alarm trigger speed (2000ppm (pulses per minute) is the default).
- Sensed temperature is above alarm trigger temperature (disabled in the default configuration).
- No temperature sensor is connected while in temperature control mode.

I2C BUS PROTOCOL

The I2C Bus is configured as a slave device that can transmit and receive data. When the Vortex is configured for I2C based speed control, the user can write speed commands to the Vortex and read all alarm status bits. When configured for temperature based control the user can read all alarm status bits from the Vortex. Writing an I2C speed command changes the control mode from temperature based to I2C based. All write registers are retained through power cycles via EEPROM.

Specifications

- The bus supports seven-bit addressing and only acts as a slave device.
- The address for the fan controller is 0x0C ('0001100') when the ID pin is pulled low. The address for the fan controller is 0x0D ('0001101') when the ID pin is pulled high or floating.
- General call support is not provided.
- The fan controller will stretch the clock further if needed. The I2C master must observe clock stretching.
- The hardware register will support Standard Mode I2C with speeds up to 100 KHz, however, lower clock speeds are recommended for increased noise immunity.
- If temperature control mode is disabled and I2C speed mode is used, then I2C communication must occur within ~2 minutes of the last communication, or there will be an I2C communication timeout error. When an I2C timeout occurs, full supply voltage will be applied to the fans, and fan speed must be reset with a new speed command. Performing any valid I2C operation on a bus will clear the timeout condition and restart the watchdog timer.

SmartFan Vortex Datasheet

- Fan failure based on 2000 minimum PPM of fan in slow (default) mode or 4000 minimum PPM in fast mode. Fan failure is not updated when the output is set to 0 VDC.
- It is possible for noise to cause the I2C hardware to miss an address or data. In this case an Ack will not be generated. The production tester allows 3 errors to occur before marking the board as failing. Also during the write cycle the I2C will not generate ACK signals as no more data can be accepted until the write to EEPROM cycle is complete. Typical write cycle is 8ms.

Table 4: I2C Bus Definitions

ACK	Acknowledge
AKK	Not Acknowledge (End of Transmission)
A6 – A0	Address for Fan Controller, bits 6 – 0
D7 – D0	Data TO/FROM Fan Controller, bits 7 – 0
L7 – L0	Data location being accessed, bits 7-0
P	Stop bit
R	Read Bit (1)
S	Start Bit
W	Write Bit (0)

Write sequence

S A6 A5 A4 A3 A2 A1 A0 W Ack L7 L6 L5 L4 L3 L2 L1 L0 Ack D7 D6 D5 D4 D3 D2 D1 D0 Ack P

Read sequence

S A6 A5 A4 A3 A2 A1 A0 W Ack L7 L6 L5 L4 L3 L2 L1 L0 Ack P S A6 A5 A4 A3 A2 A1 A0 R Ack D7 D6 D5 D4 D3 D2 D1 D0 Ack P

Register Locations: L7-L0 Label (R/W) [initial condition]

Register 0x00 – 0xEF: Generic EEPROM storage (R/W) [undetermined]

Register 0xF0: Firmware Revision (Read only) [00:current rev]

Register 0xF1: Alarm Status (Read only) [0x00]

D0: Status of fan on J1 (0=no fault, 1= fault)
 D1: Status of fan on J2 (0=no fault, 1= fault)
 D2: Status of fan on J3 (0=no fault, 1= fault)
 D3: Status of fan on J4 (0=no fault, 1= fault)
 D4: Status of speed override (0=normal, 1=12VDC)
 D5: Status of on-board sensor (0=connected, 1= open)
 D6: Status of external sensor (0=connected, 1=open)
 D7: Status of controlling sensor (0=valid, 1=alarm)

Register 0xF2: Temperature (Read only) [1111 1111] on-board sensor

D0-7: Temperature from 0 - 70 in deg. C in 0.5 deg steps
 255 = temperature not read yet or open
 254 = temperatures above 70

Register 0xF3: Temperature (Read only) [1111 1111] external sensor

D0-7: Temperature from 0 - 70 in deg. C in 0.5 deg steps
 255 = temperature not read yet or open
 254 = temperatures above 70

Register 0xF4: Current Target Speed (Read only) [0000 1100]

D0-7: 0x0C = 12 VDC, 0x06 = 6VDC
 Commanded speed with alarm status override included
 In temperature mode this register will read 0x0C

Register 0xF5: Current Speed (Read only) [0000 1100]

D0-7: 0x0C = 12 VDC, 0x06 = 6VDC
 What the actual current voltage is
 In temperature mode this register will read 0x0C

Register 0xF6: Commanded Speed (R/W) [1111 1111]

D0-3: 0x0C = 12 VDC, 0x06 = 6VDC, 0x00 = off
 If set to 0xFF then temperature mode is enabled and I2C speed control disabled

Register 0xF7: Off Temperature (R/W) [1111 1111]

D0-7: Temperature from 0 - 70 in degrees C in 0.5 deg steps below which the controller turns off the fan output (0 VDC)
 If set to 0xFF then function disabled

Register 0xF8: Control Temperature (R/W) [0101 0000]

D0-7: Temperature from 0 - 70 in degrees C in 0.5 deg steps where fans reach full speed in temperature mode.
 Only used if Commanded Speed set to 0xFF.

Register 0xF9: Alarm Temperature (R/W) [1111 1111]

D0-7: Temperature from 0 - 70 in degrees C in 0.5 deg steps above which the controller alarms
 If set to 0xFF then function disabled

Register 0xFA: Config Register (R/W) [0000 1111]

D0-D3: 0=Mask, 1=Active for an Fan (J1-J4)
 D4: 0=P series sensor, 1=S series sensor.
 D5: 0=5deg slope, 1=10 deg slope for temperature mode only
 D6: 0=2000PPM tach, 1=4000PPM tach fan alarm speed
 D7: 0=External, 1=On-board sensor selection for temperature mode only

Register 0xFB-0xFF: CRI Test Register (Reserved) [xxxx xxxx]

D0-7: Do not use

Note: If a fan failure occurs the Current Speed will be updated to 12V but the Commanded Speed will remain at its previous value. Once the failure clears the Current Speed will return to the Commanded Speed value. An I2C timeout changes BOTH the Current Speed and Commanded Speed to 12V. The Commanded Speed must be reset after a timeout. During the speed ramp the Current Speed will not match the Commanded Speed until the ramp completes.

